

## ZT-50RA / ZT-100RA

### Fyreye 50/100R Addressable Reflective Beam Smoke Detector



The Fyreye Reflective Beam Detector comprises a single unit incorporating an Infra-red transmitter and receiver. The signal is reflected by a prism and analysed for smoke presence.

Should a predetermined level be reached, the detector will signal an alarm.

The system is designed to be mounted so that the beam will project between 0.3 and 0.6 metres below the ceiling, and parallel to it. Lateral detection may be up to 7.5 metres either side of the beam.

Features include:-

- Single compact housing.
- 50 metre or 100 metre version available.
- Horizontal or vertical mounting.
- 12-24V dc operation.
- Low current consumption.
- Latching or non latching alarm.
- Reflector targeting mode to

ease set-up.

- Microprocessor controlled.
- Automatic contamination compensation.
- Selectable sensitivity.
- Robust construction.
- Conforms to:
  - BS 5839 Part 5
  - EN54 Part 12
  - UL
  - VDS

#### Typical Applications

Beam detectors are generally used for 2 reasons; to cover a wide-open space, or in places where several regular smoke detectors would be aesthetically unacceptable. Such places could include:

- Shopping Centres
- Heritage sites
- Churches or Mosques
- Museums
- Leisure centres
- Open Plan offices
- Warehouses
- Factories
- Power stations, etc.

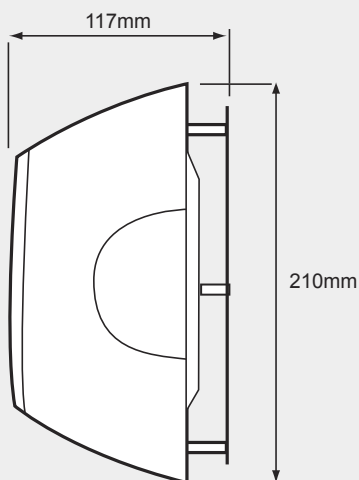

MODEL	ZT-50RA	ZT-100RA
PART NO.	47-055	47-056
SUPPLY VOLTAGE	17-33VDC	
RANGE	5-50 metres	50-100 metres
QUIESCENT CURRENT	5mA	
OPERATING TEMP.	-20 °C to +55 °C	
MAX HUMIDITY	95%RH N/C	
MAX WIND SPEED	Not affected	
ALARM CURRENT	9 mA	
FIRE OUTPUT	Analogue value to panel	
FAULT OUTPUT	Analogue value to panel	
CONSTRUCTION	Flame Retardant ABS (Grey / Black). IP50	
DETECTOR SIZE	210 x 117 x 120 mm	
WEIGHT	0.7 kg	